

DSL *Fire SAFE*

DSL Safe is the best solution against fires.



Recessed double curvature frames provide virtually airtight construction preventing smoke and heat damage.

At no extra cost, key locking compartment drawer is provided. (Above Model 006)

Spacious interior dimensions allow for more efficient and larger storage area.

2 or 3 way (up and side) active bolts and dead bolts provide.

Fully adjustable shelf or shelves

Re-locker(s) provides more security. (Above Model 006)

Rust Free
100% top quality EGI steel plate and antirust refined durable paint keep rust free. Every safe is cleaned to remove toxic foreign matters before painting.

Top quality urethane antirust primer coated. Durable acrylic urethane leather-tone finish in smart modern colors makes the surface more smooth and bright, preventing scratches and worn-out.



Alarm system available
Once alarm system is affected by shock, vibration or tilt, it makes horn immediately.

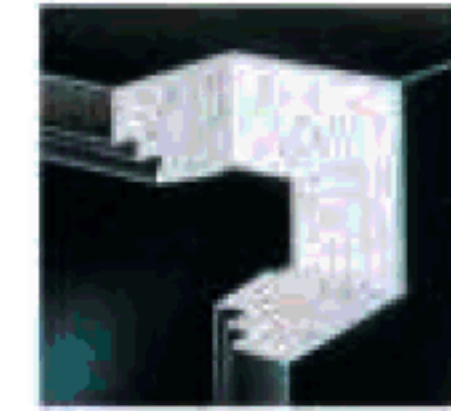

Amazing fire resistant Insulation STYRONITE F

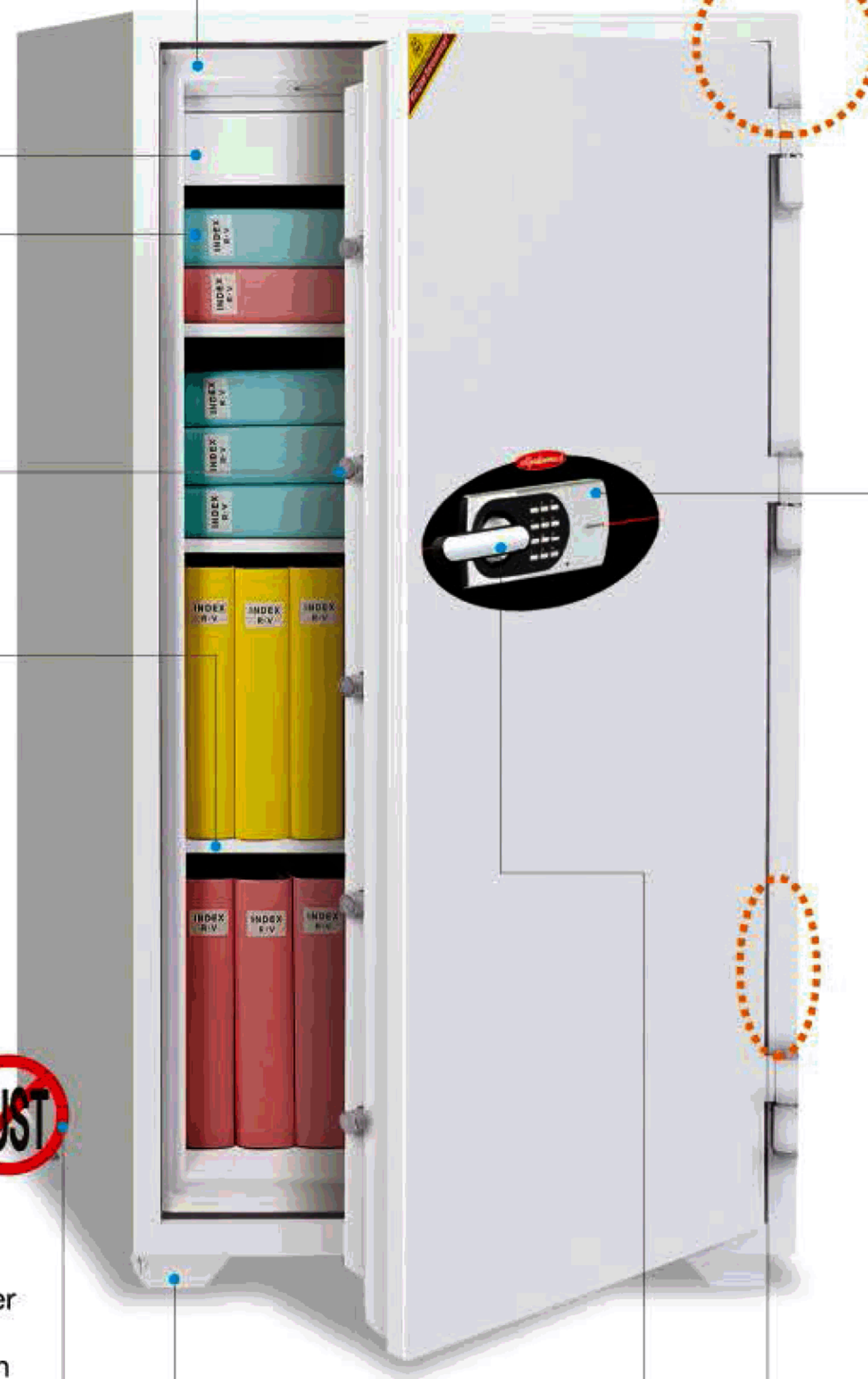

Wheels removable (option)

Available Electronic Digital Lock



EDL77(EN)



EDL77(EK)



EDL77(EH)



TSL



TSL-K



FPL



REDL2

Optional Mechanical Lock

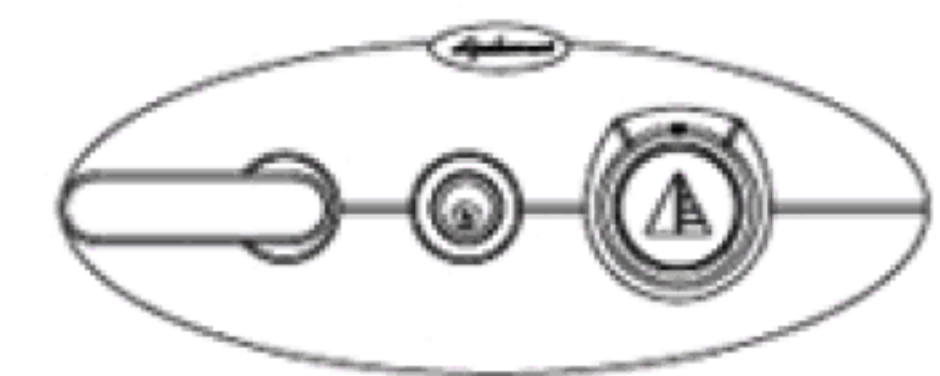

Optional Vision-guard Dial Lock
spy-proof 4-tumbler combination lock

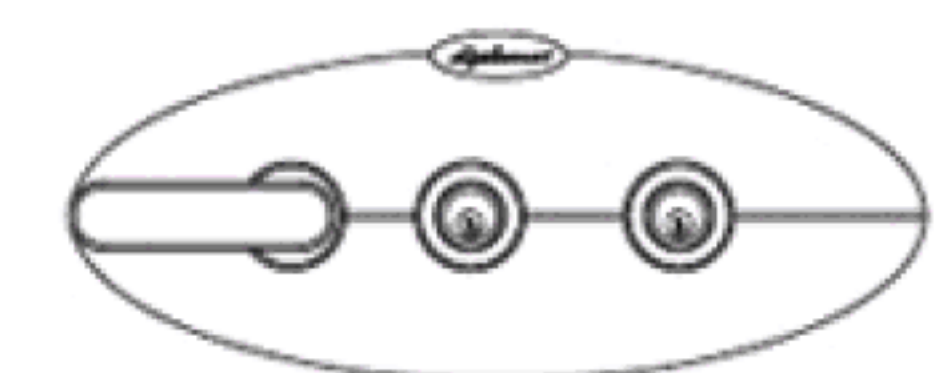

Optional Double Key-locks

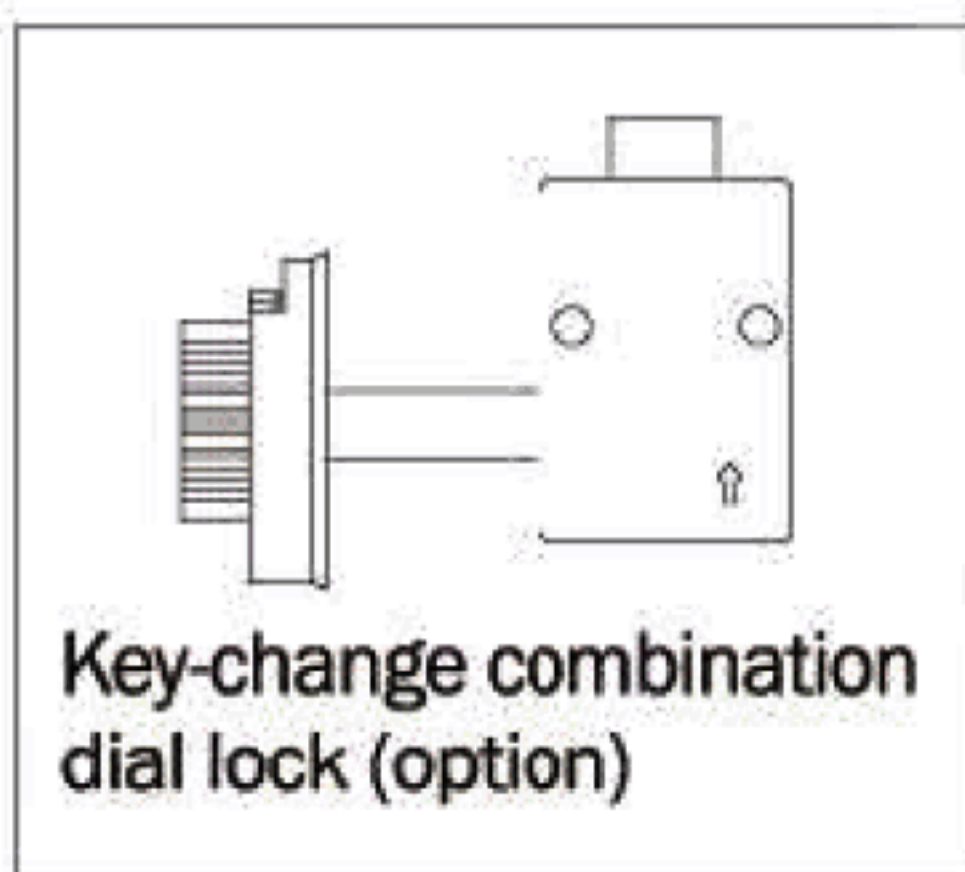

Key-change combination dial lock (option)

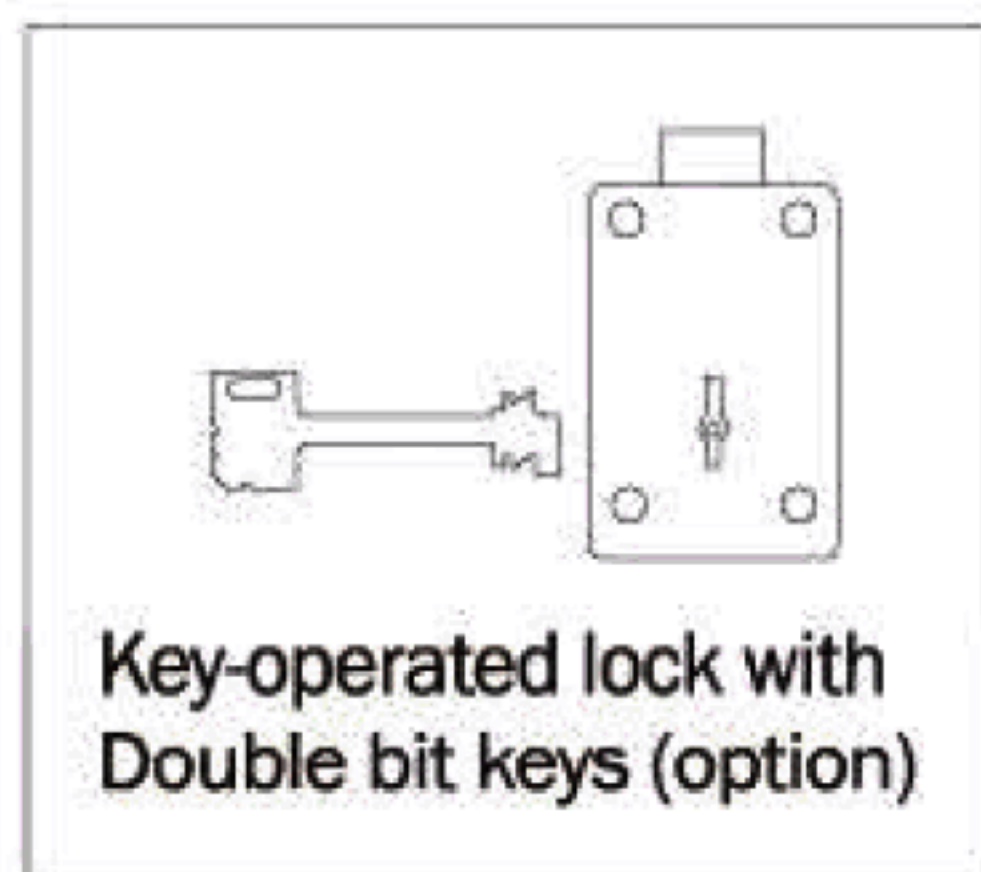

Key-operated lock with Double bit keys (option)

Handle snaps into position automatically when door is closed.

Recessed double curvature frames from top end to bottom end work as dead bolts.

Home Safe

Keyless push button Electronic Digital Lock(EDL) safes offer comfort, Convenience and reliability. Your memory is just a key. For dual guard, a key lock can be added in option.

Plastic Trays available



■ H x W x D = High x Wide x Deep

	001EN	119EN	125EN	530EN	006EH
Outside (mm)	H308 x W410 x D342	H360 x W412 x D363	H420 x W352 x D433	H522 x W404 x D440	H538 x W450 x D460
Inside (mm)	H220 x W330 x D225	H260 x W320 x D234	H320 x W260 x D304	H410 x W300 x D300	H430 x W350 x D328
Weight (kg)	26	31	36	53	64
Capacity (ℓ)	16	19	25	36	49
Tray (pc)	-	1	1	1	1
Shelf (pc)	-	-	1	1	1
Fire Class	-	60 Paper	60 Paper	60 Paper	60 Paper

- Outside dimension includes the height of plastic feet of 8mm.
- EDL used on the above models is a solenoid type(001~530) or a swing-bolt type(006).

Available Locking System & Front Face

- Digital Lock

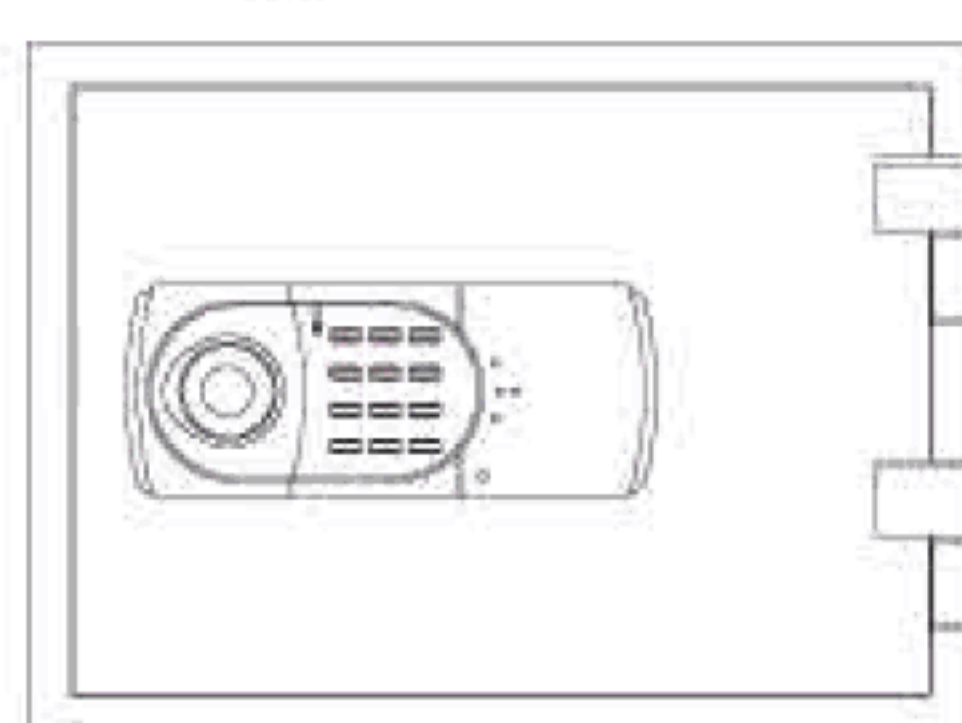

EN
(EDL77 + Knob)

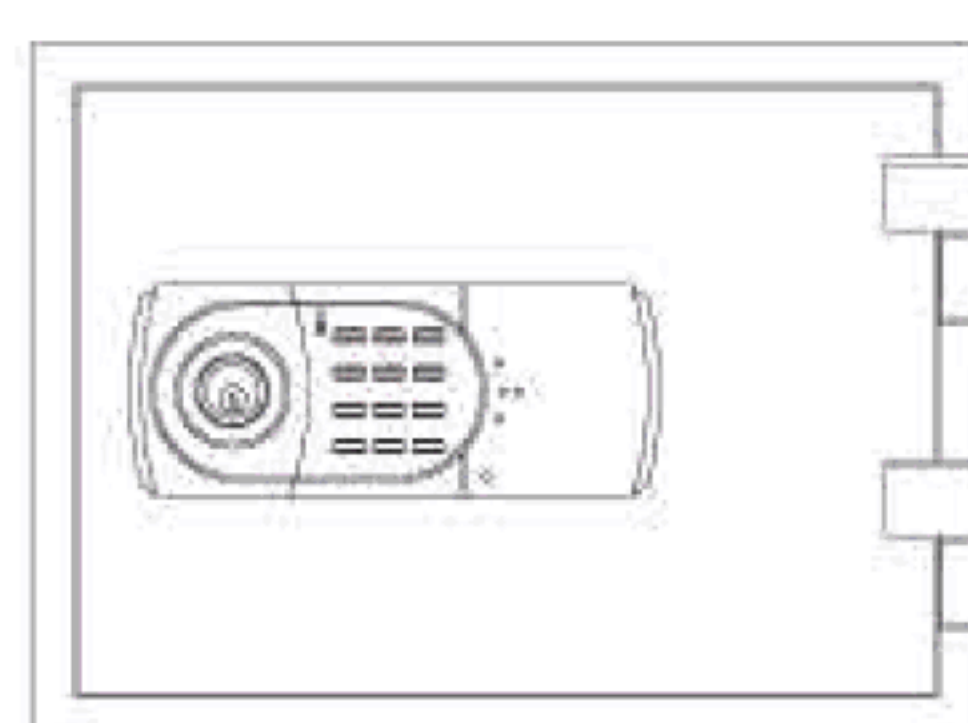

EK
(EDL77 + Keylock)



RH
(REDL2 + Handle)

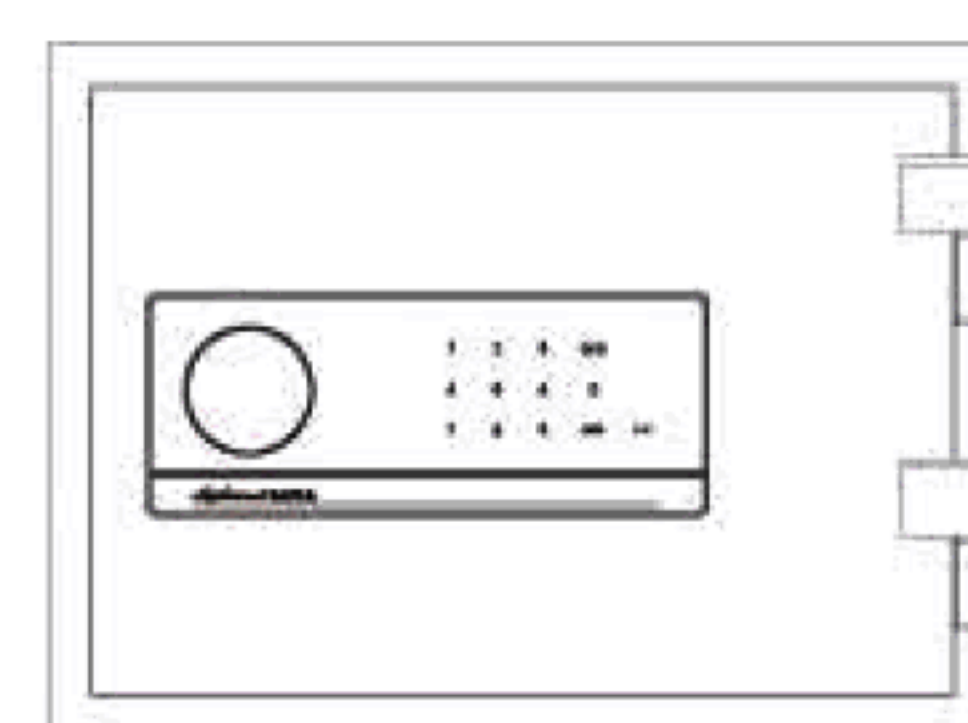

TSL
(Touch Screen Lock)

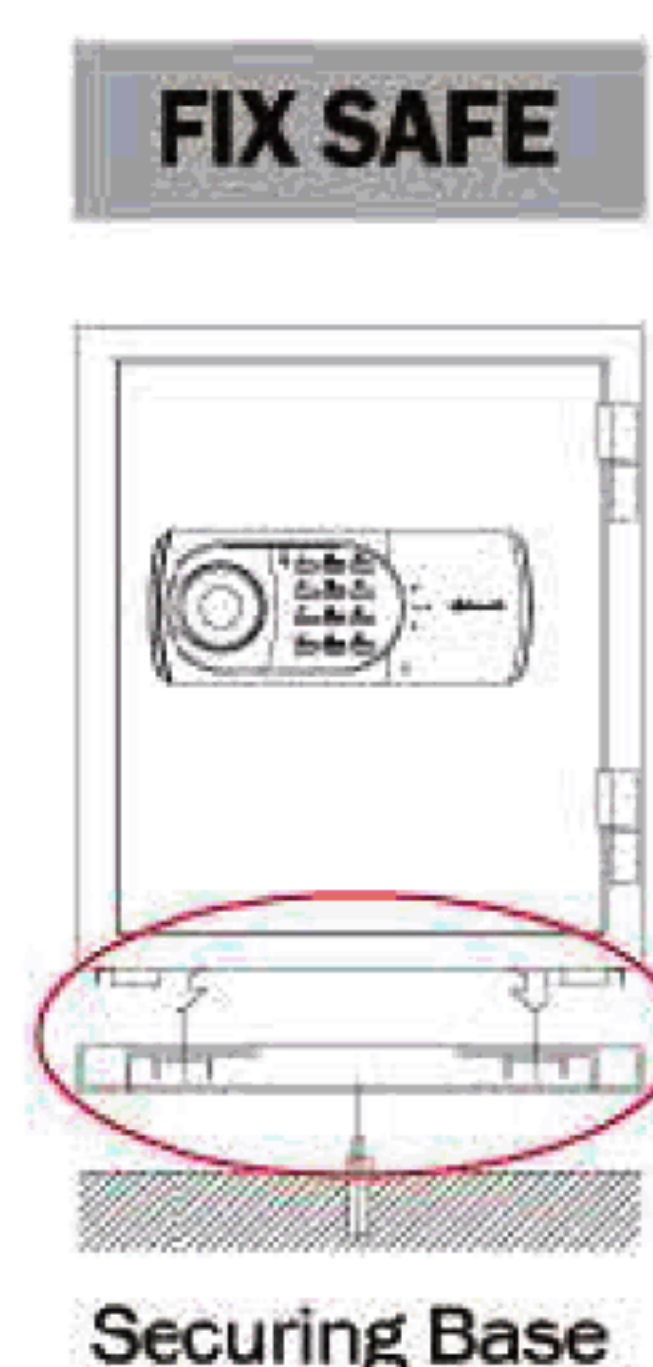

FIX SAFE

Securing Base

Home & Office Safe

We recommend technically advanced Electronic Digital Lock(EDL) safe for better reliability and convenience at home or in the office.

At very reasonable price you may choose a magnificent safe for any purpose.

Take one at home or to the office, and enjoy both convenience and security.



■ H x W x D = High x Wide x Deep

	060EH	070EH	080EH	060VR
Outside (mm)	H660 x W470 x D470	H695 x W500 x D500	H876 x W520 x D520	H660 x W470 x D470
Inside (mm)	H480 x W350 x D300	H515 x W380 x D330	H676 x W380 x D330	H480 x W350 x D300
Weight (kg)	80	90	122	80
Capacity (ℓ)	50	64	84	50
Tray (pc)	1	1	1	1
Shelf (pc)	1	1	1	1
Fire Class	90 Paper	90 Paper	90 Paper	90 Paper

- Height includes Wheels of 60mm.
- EDL used on the above models is a swing bolt type.

Available Locking System & Front Face

- Digital Lock

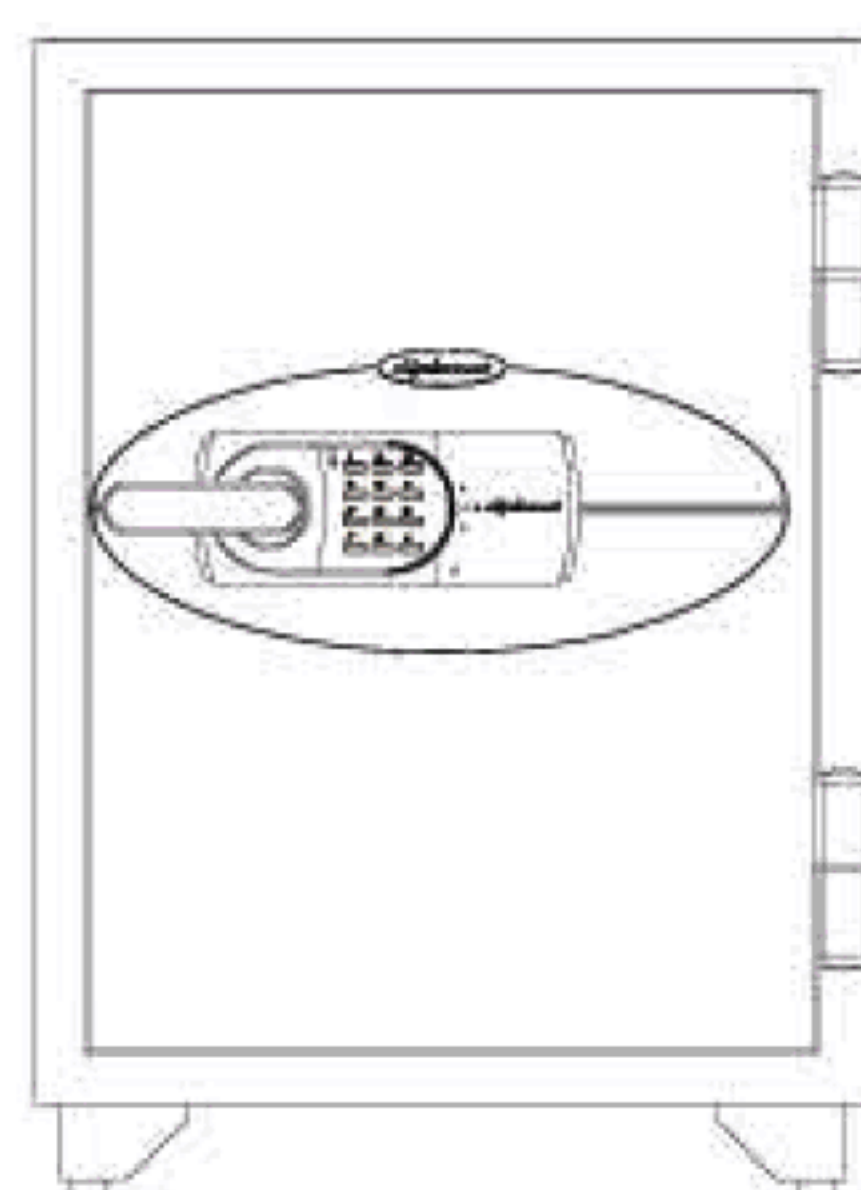

EH
(EDL77 + Handle)

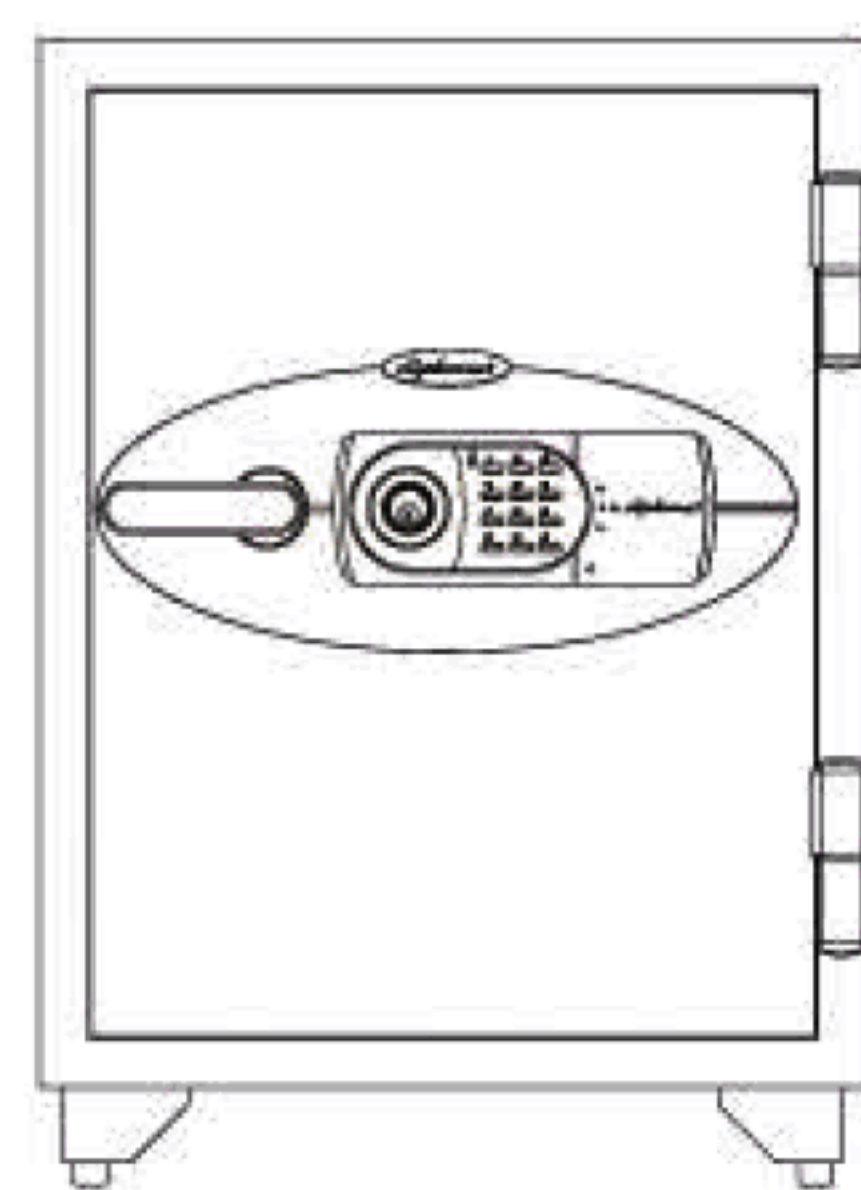

EHK
(EDL77 + Keylock + Handle)

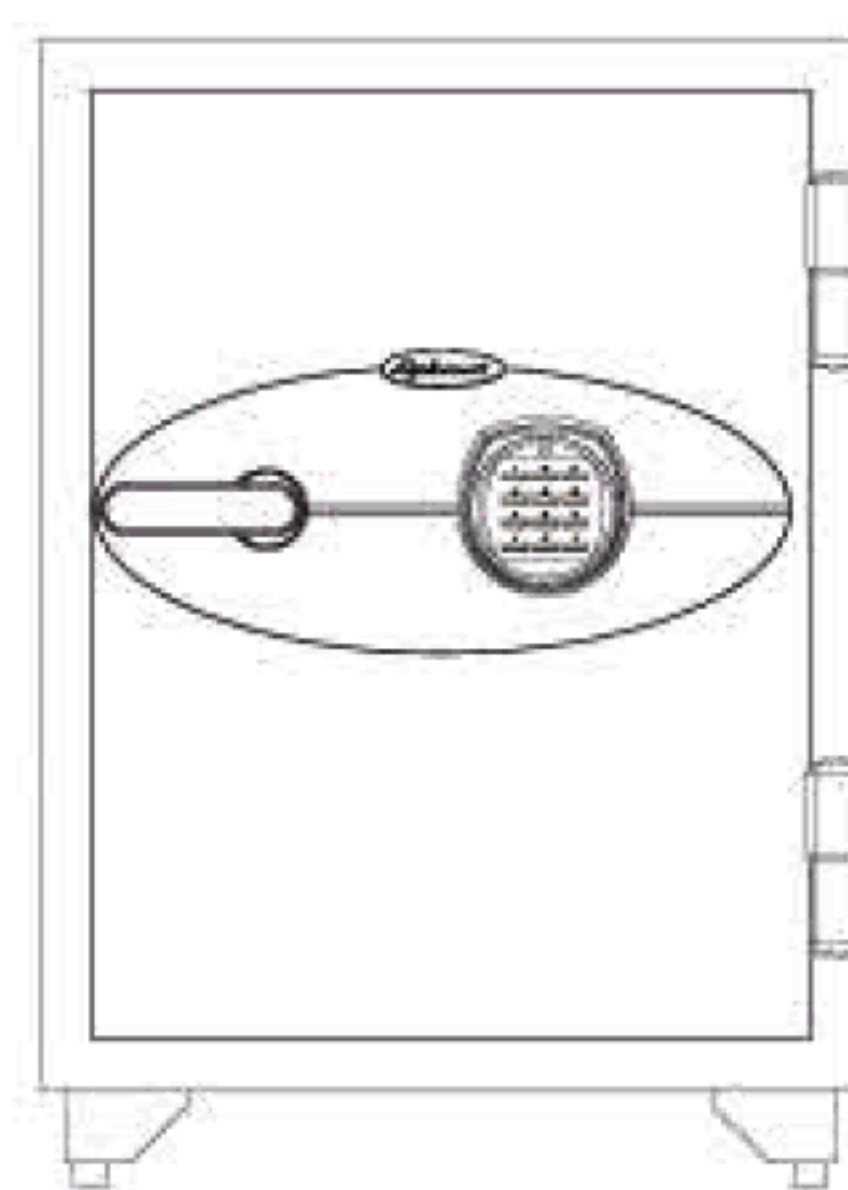

REH
(REDL2 + Handle)

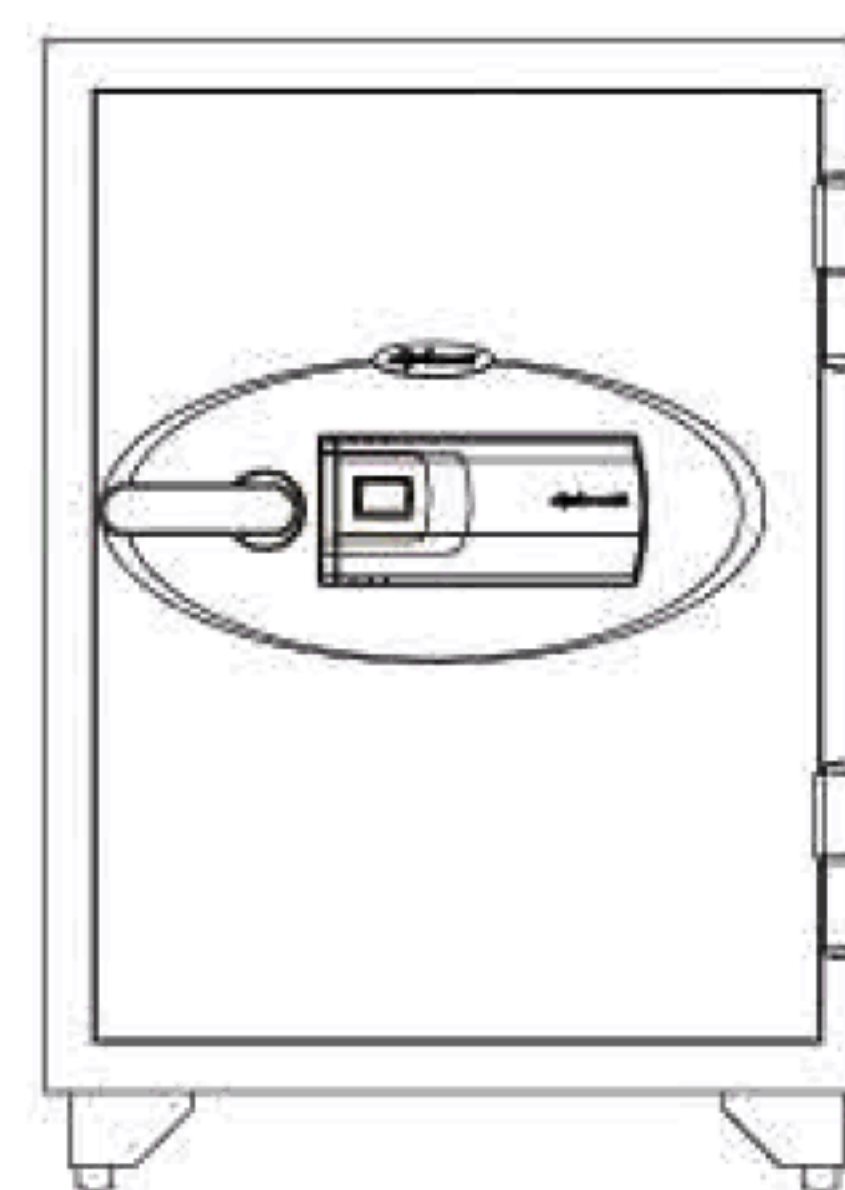

FPL 070 up to 300
(Finger Print Lock + Handle)

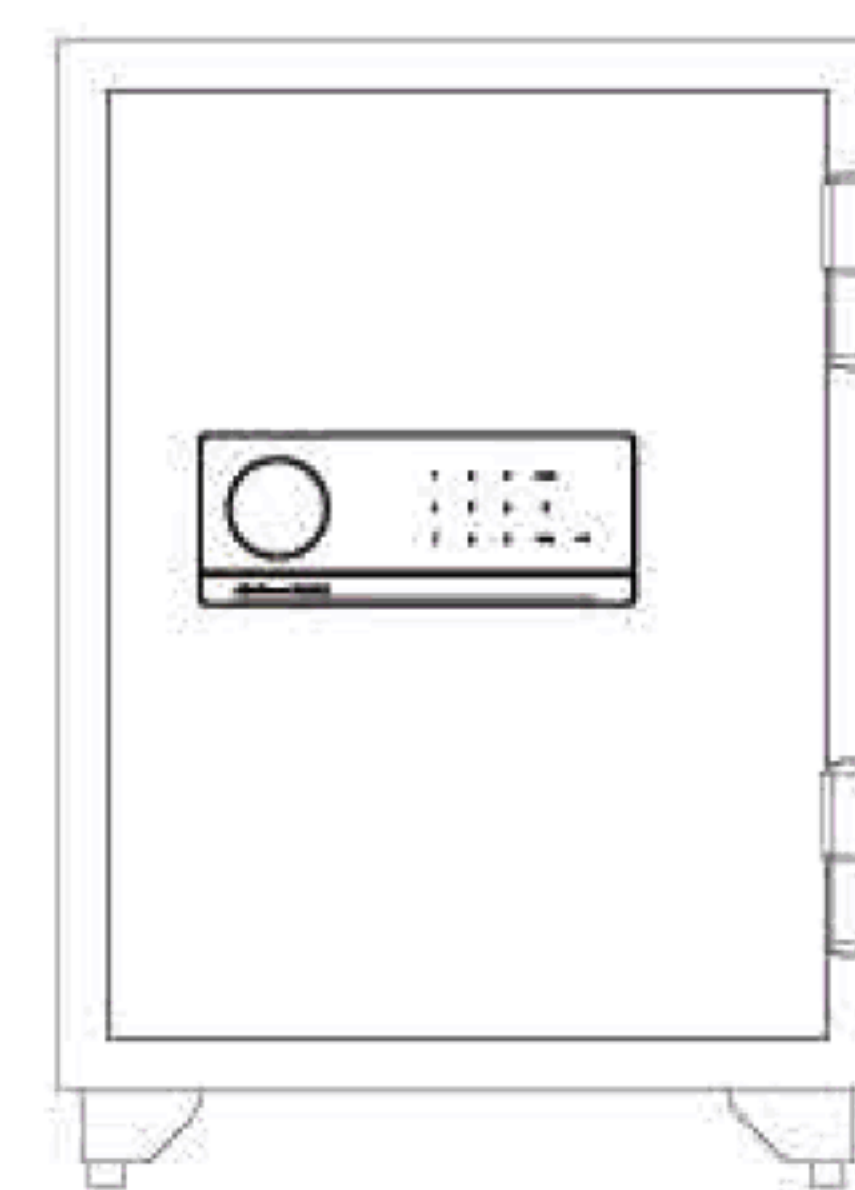

TSL 060 up to 300
(Touch Screen Lock)

Office Safe

It's more convenient for the people who'd like to desire more comfortable and convenient life. If you are requested to open your safe more than three times a day, we strongly recommend **EDL SAFE** wherever it is used at home in the office or in the store.



825EH

100EH / 110EH / 120EH

130EH

200EH

■ H x W x D – High x Wide x Deep

	825EH	100EH	110EH	120EH	130EH	200EH
Outside (mm)	H830 x W690 x D720	H1020 x W655 x D560	H1120 x W655 x D560	H1220 x W655 x D560	H1445 x W775 x D650	H1690 x W775 x D650
Inside (mm)	H590 x W510 x D510	H780 x W475 x D350	H880 x W475 x D350	H980 x W475 x D350	H1205 x W595 x D440	H1450 x W595 x D440
Weight (kg)	203	201	209	228	348	388
Capacity (ℓ)	153	129	146	162	315	379
Tray (pc)	1	1	1	1	1	1
Shelf (pc)	1	2	2	2	3	3
Fire Class	120 Paper	120 Paper	120 Paper	120 Paper	120 Paper	120 Paper

- Height includes Wheels of 60mm.
- EDL used on the above models is a swing bolt type.

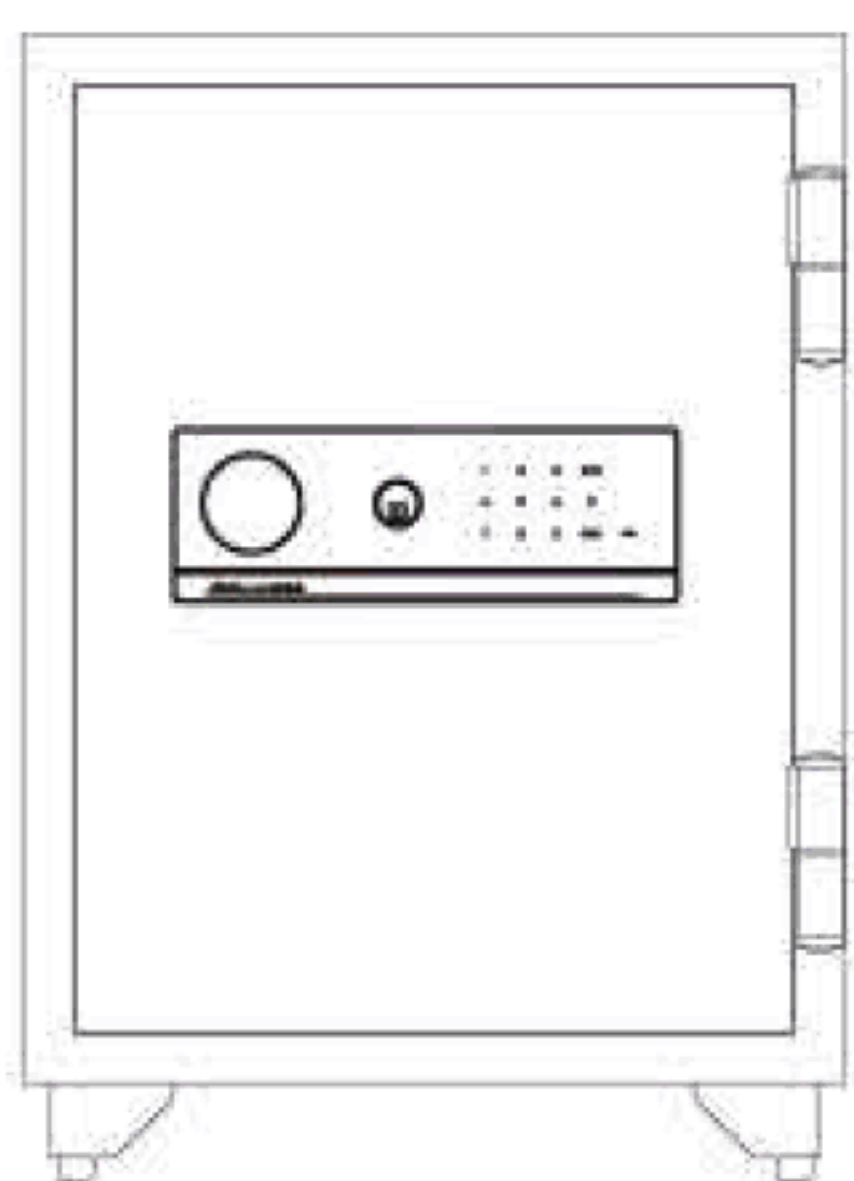

TSL-K 060 up to 300
(Touch Screen Lock + Keylock)

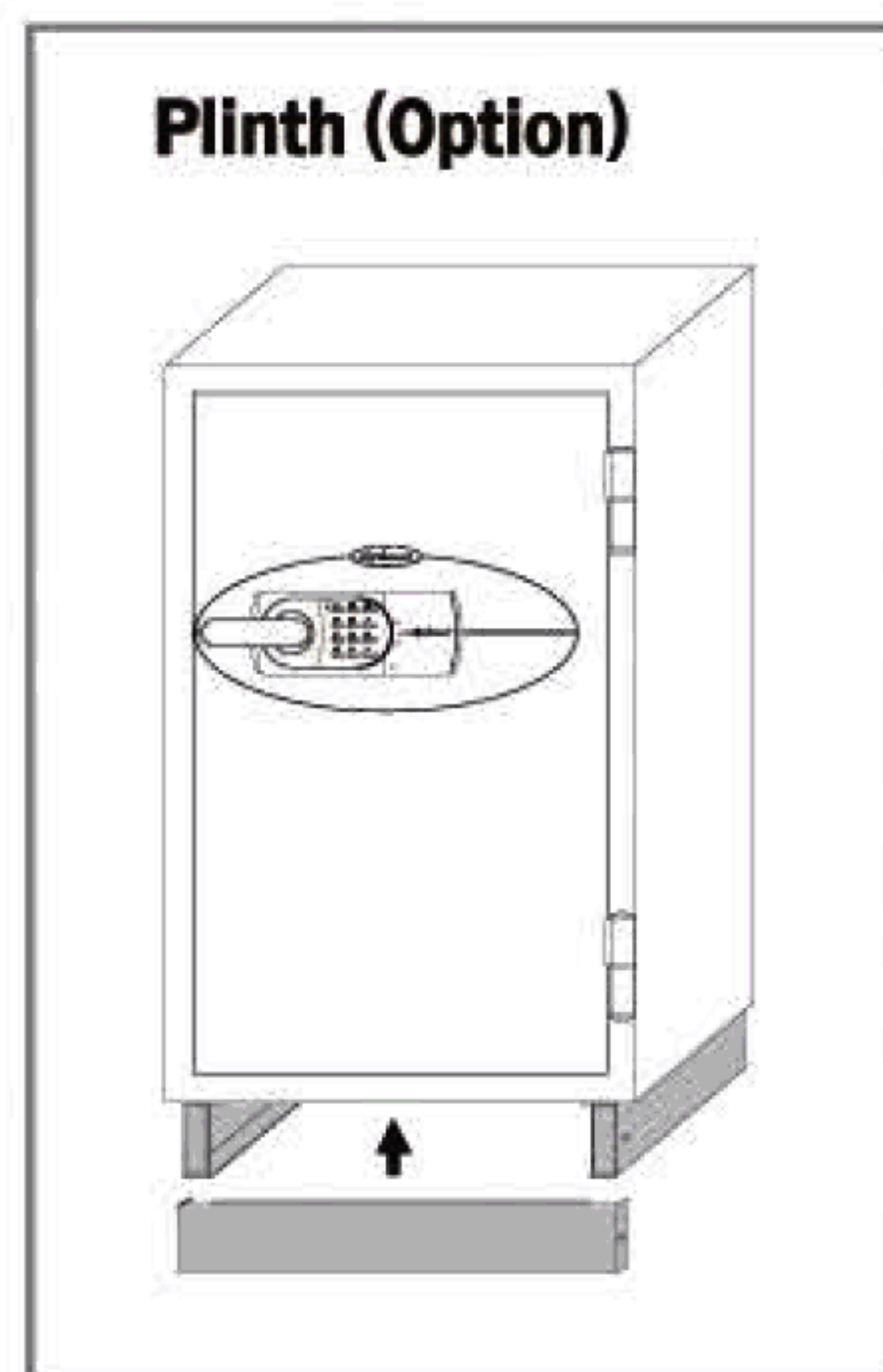

Plinth (Option)

Double Door Safe

Some businesses often require very special size safes in dimensions for some irregular binders, drawings or office equipments. These safes can be modified to install inner boxes for special purposes or user's needs.



S300EH

M300EH

L300EH / W300EH

C300EH

■ H x W x D = High x Wide x Deep

	S300EH	M300EH	L300EH	W300EH	C300EH
Outside (mm)	H1220 x W950 x D700	H1495 x W1126 x D700	H1745 x W1126 x D700	H1745 x W1200 x D720	H1925 x W950 x D560
Inside (mm)	H980 x W770 x D490	H1255 x W946 x D490	H1505 x W946 x D490	H1505 x W1020 x D510	H1685 x W770 x D350
Weight (kg)	350	480	540	560	470
Capacity (ℓ)	370	582	698	783	454
Tray (pc)	2	2	2	2	-
Shelf (pc)	2	3	3	3	4
Fire Class	120 Paper	120 Paper	120 Paper	120 Paper	120 Paper

- Height includes Wheels of 60mm.
- EDL used on the above models is a swing bolt type.

Available Locking System & Front Face

- Digital Lock

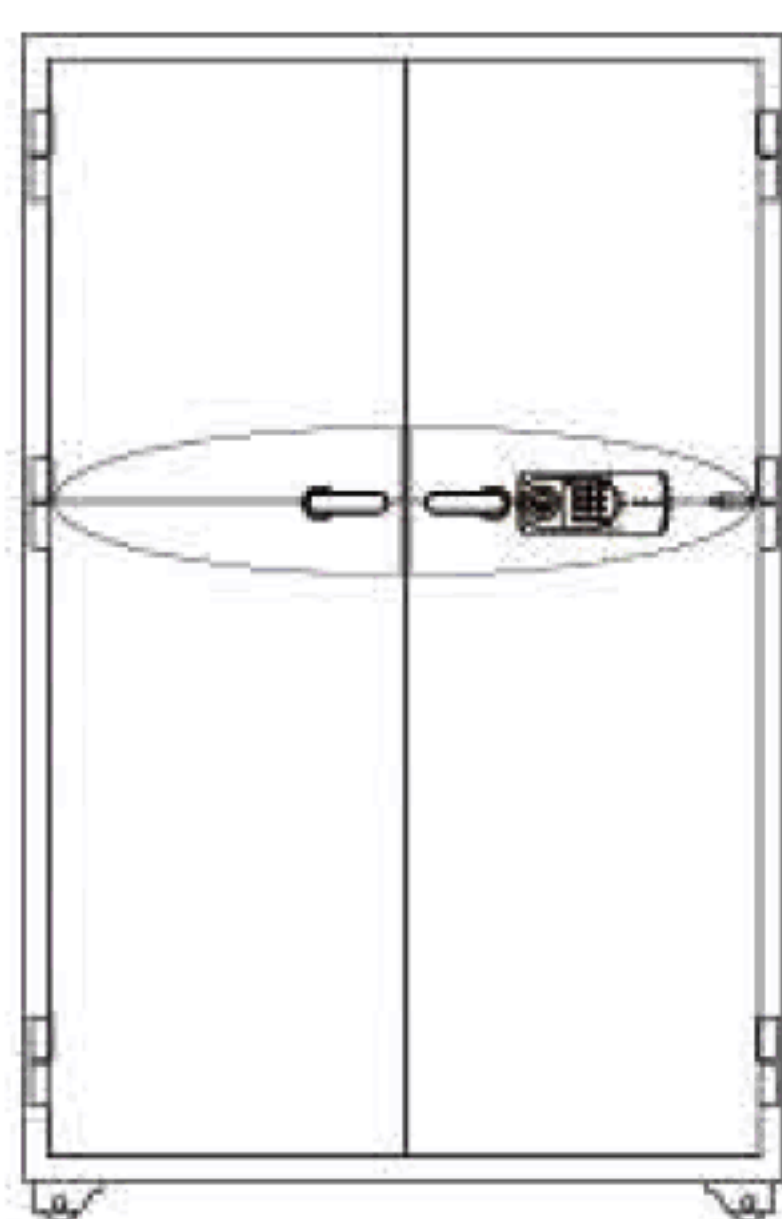

EHK
(EDL77 + Keylock + Handle)

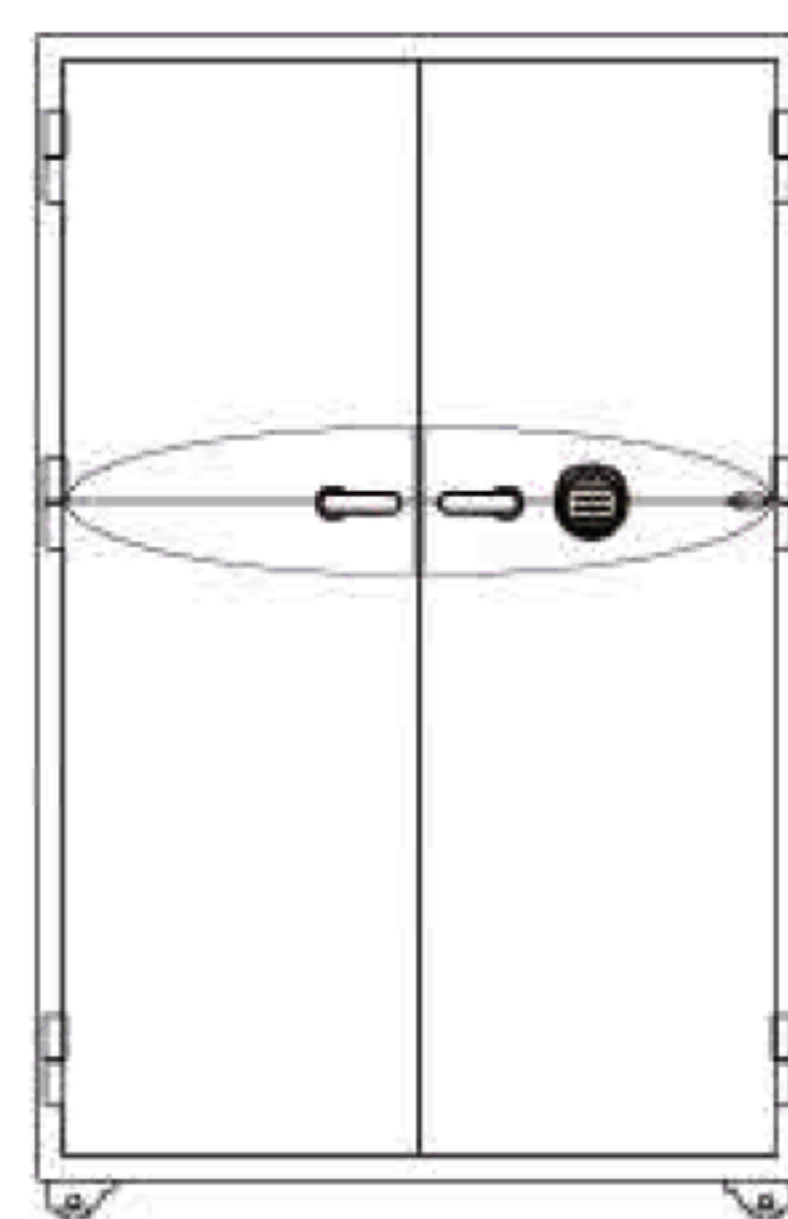

REH
(REDL2 + Handle)

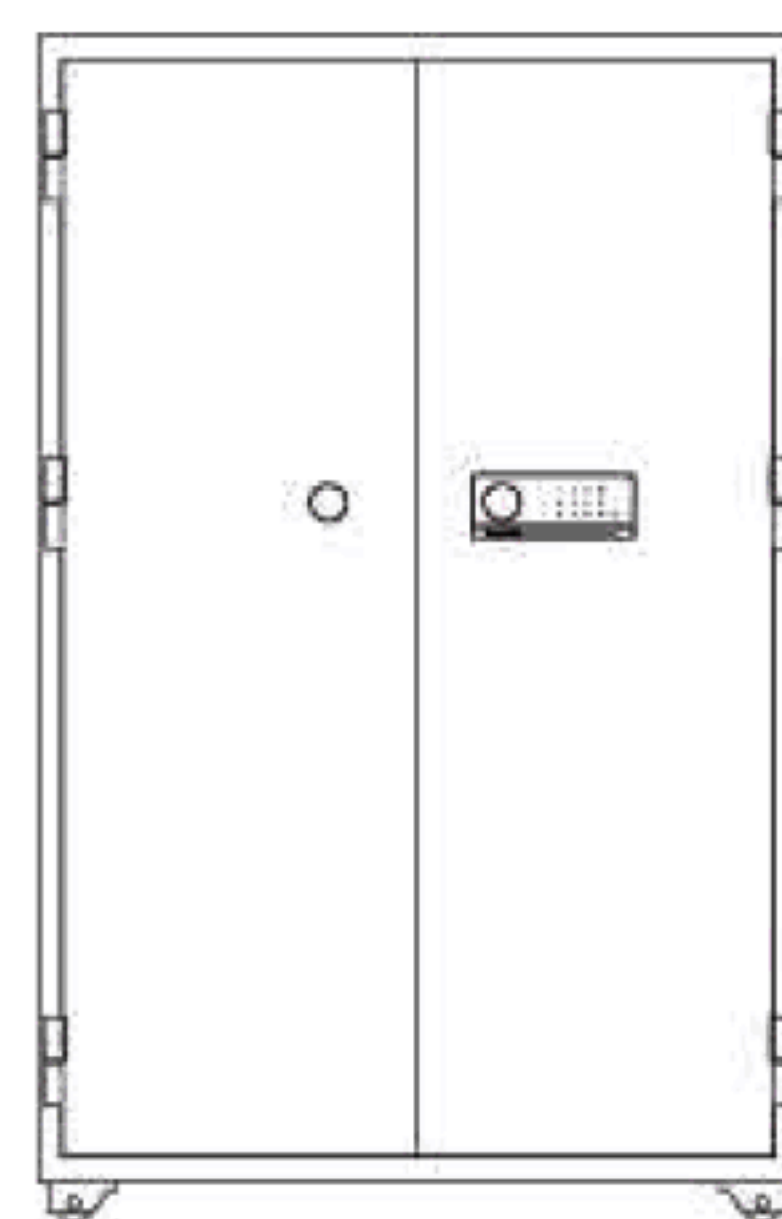

TSL
(Touch Screen Lock)



TSL-K
(Touch Screen Lock + Keylock)

Burglary & Fire Protection Safe

Strong Steel Box installed.



BF070EH

BF080EH

BF100EH / BF110EH / BF120EH

BF130EH / BF200EH

■ H x W x D = High x Wide x Deep

	BF070EH	BF080EH	BF100EH	BF110EH
Outside (mm)	H695 x W500 x D500	H876 x W520 x D520	H1020 x W655 x D560	H1120 x W655 x D560
Inside (mm) Except Steel Box	H295 x W380 x D330	H456 x W380 x D330	H480 x W475 x D350	H580 x W475 x D350
Capacity (ℓ)	37	57	80	96
Inner Steel Box (mm)	H214 x W372 x D226	H214 x W372 x D226	H294 x W467 x D246	H294 x W467 x D246
Capacity (ℓ)	18	18	42	42
Weight (kg)	111	143	232	240
Tray / Shelf (pc)	1 / -	1 / 1	1 / 1	1 / 1
Fire Class	90 Paper	90 Paper	120 Paper	120 Paper

	BF120EH	BF130EH	BF200EH
Outside (mm)	H1220 x W655 x D560	H1445 x W775 x D650	H1690 x W775 x D650
Inside (mm) Except Steel Box	H680 x W475 x D350	H855 x W595 x D440	H1100 x W595 x D440
Capacity (ℓ)	113	224	288
Inner Steel Box (mm)	H294 x W467 x D246	H344 x W587 x D336	H344 x W587 x D336
Capacity (ℓ)	42	68	68
Weight (kg)	259	379	419
Tray / Shelf (pc)	1 / 1	1 / 2	1 / 2
Fire Class	120 Paper	120 Paper	120 Paper

■ Inner Steel box with EDL77. ■ Height includes Wheels of 60mm. ■ EDL used on the above models is a swing bolt type.

Available Locking System & Front Face

- Digital Lock

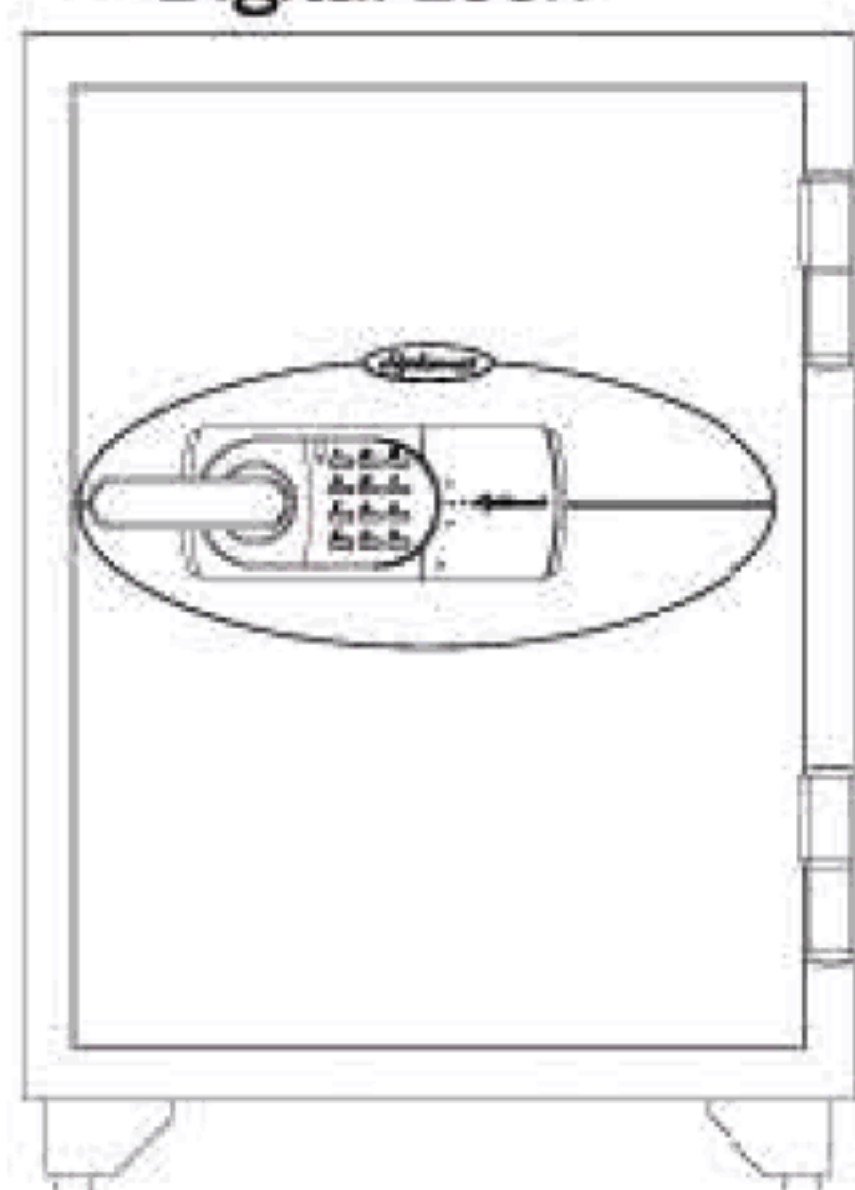

EH
(EDL77 + Handle)

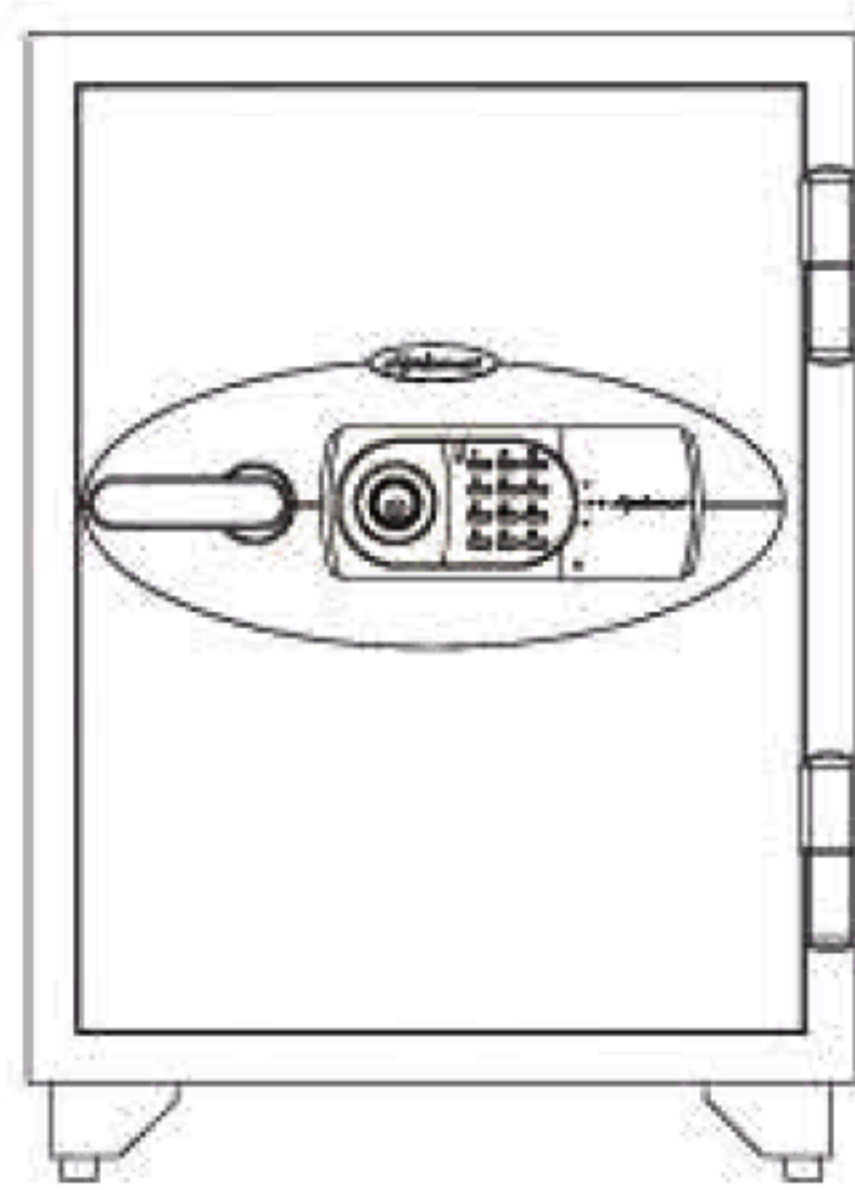

EHK
(EDL77 + Keylock + Handle)

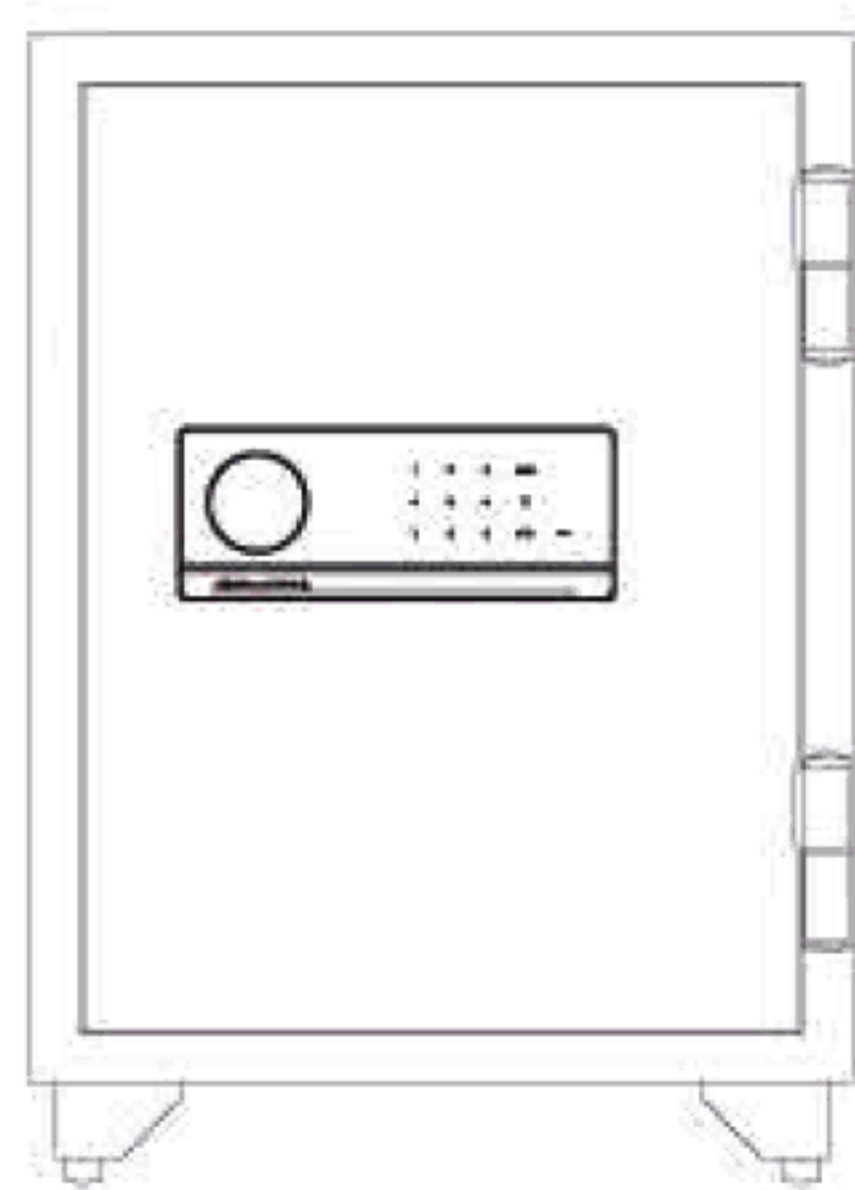

TSL
(Touch Screen Lock)

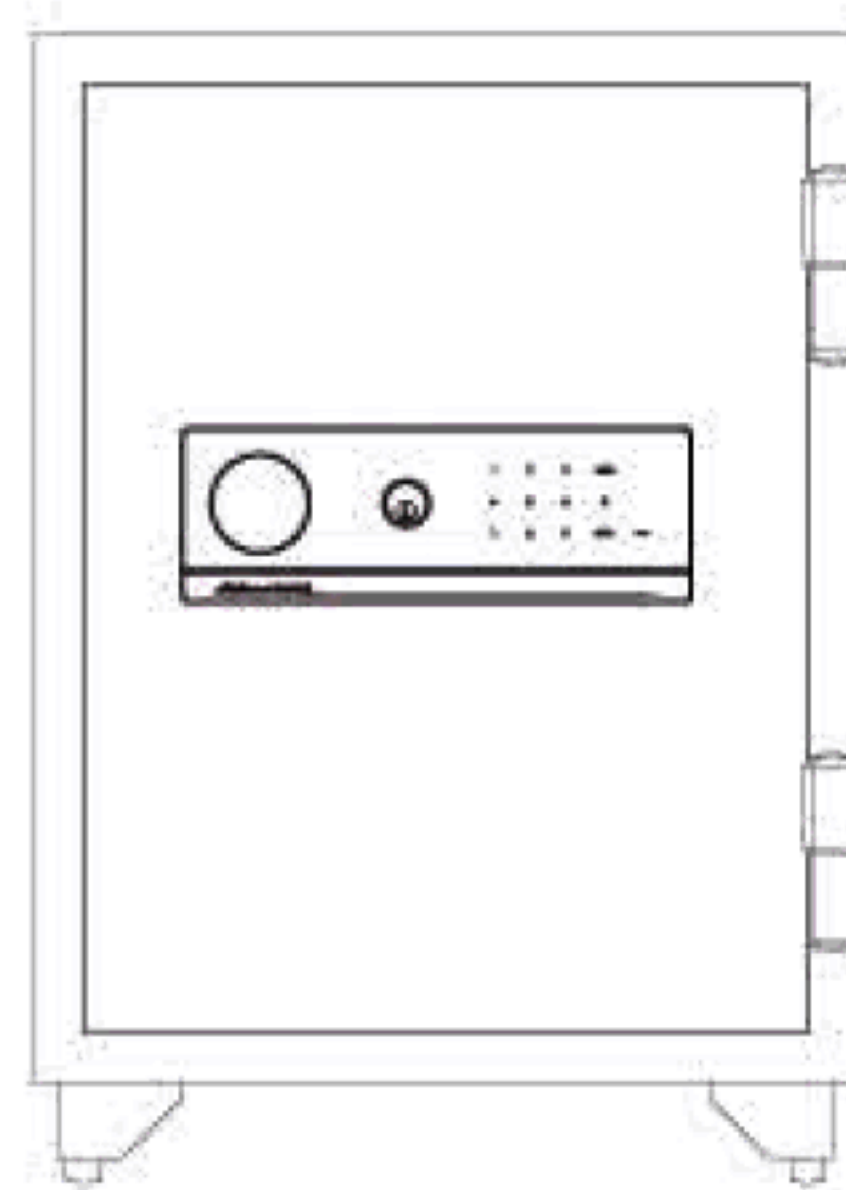

TSL-K
(Touch Screen Lock + Keylock)

Strong Steel Box

